

Logic[®]
SOUNDLAB

USER'S MANUAL



LSX1002
LSX1204
LSX1402
LSX1804
LSX2002
LSX4000D
LSX5000D

CONTENTS

Introduction	2	LSX1002
Features & Specifications	3-4	LSX1204
Built-in Crossover	4	LSX1402
About Protection Circuit	4	LSX1804
2 Ohm Operation	5	LSX2002
Electrical Wiring	5	LSX4000D
Power Fuses	5	LSX5000D
Mounting the Amplifier	5	
Power Supply Connections	6	
Two Channel Speaker wiring	6-8	
Four Channel Speaker wiring	8-12	
Class D Monoblock Installation Wiring	12-15	
Amplifier Disassembly Instructions	16	
Remote Control	16	
Precautions	17	
Troubleshooting	17	

Introduction

Congratulations on your purchase of **Logic**[®] car audio amplifier. **Logic**[®] amplifiers are designed to the highest level of quality and offer you years of listening enjoyment.

Engineered in the USA, Logic[®] offers innovative products
That are on the cutting edge of design and performance.

Thank you for making **Logic**[®] your choice for car audio equipment.

Features

LSX1002/LSX1402/LSX2002/LSX1204/LSX1804

- Thermal/Short/Over Load Protection
- 2 Ohm Stable (4 Ohm Bridged)
- P.W.M. MOSFET Power Supply
- Power & Distress Indicator
- Variable Low-pass (40~160Hz.)
- Heavy Duty Heat Sink
- Low Level and High Level Input
- Built-in Cooling Fan with Chrome Grill
- Adjustable Input Sensitivity
- Soft Delay Remote Turn-on
- Nickel Plated Terminal Strips/RCA Jacks
- Phantom Channel for Powering Center Speaker or Sub-woofer
- Built-in Remote Jack, Remote Control is included.

LSX4000D/LSX5000D

- Thermal/Short/Over Load Protection
- 1 Ohm Stable
- P.W.M. MOSFET Power Supply
- Power & Distress Indicator
- Variable Low-pass(50~150Hz.)
- Low Level and High Level Input
- Built-in Cooling Fan with Chrome Grill
- Adjustable Input Sensitivity
- Soft Delay Remote Turn-on
- Nickel Plated Terminal Strips/RCA Jacks
- Phantom Channel for Powering Center Speaker or Sub-woofer
- Built-in Remote Jack, Remote Control is included.

Specifications

Model No.	LSX1002	LSX1402	LSX2002
MAX Power @ 2 ohm	2 x 500W	2 x 700W	2 x 1000W
RMS Power @ 4 ohm	2 x 250W	2 x 350W	2 x 500W
Bandwidth	10Hz-40KHz	10Hz-40KHz	10Hz-40KHz
Signal to Noise	≥98dB	≥98dB	≥98dB
Channel Separation	≥60dB	≥60dB	≥60dB
Input Sensitivity Range	300mv-8v	300mv-8v	300mv-8v
LP Variable Crossover	40-160Hz&12dB/octave	40-160Hz&12dB/octave	40-160Hz&12dB/octave
HP Variable Crossover	40-600Hz&12dB/octave	40-600Hz&12dB/octave	40-600Hz&12dB/octave
Variable Bass Boost	0 - +18dB@45Hz	0 - +18dB@45Hz	0 - +18dB@45Hz
Variable Subsonic Filter	20-55Hz&12dB/octave	20-55Hz&12dB/octave	20-55Hz&12dB/octave
High Level Input	YES	YES	YES
Phase	----	----	----
Line out RCA jack	YES	YES	YES
RCA Input Model	----	----	----
Input Impedance	20K Ohms	20K Ohms	20K Ohms
Damping factor	≥200	≥200	≥200
T.H.D (4 Ohm)	0.01%	0.01%	0.01%
Fuse Rating	30A	20Ax2	30Ax2
Dimensions(WxLxH) inches	12.44"x 9.57"x2.76"	14.41"x9.57"x 2.76"	17.17"x 9.57"x 2.76"

Model No.	LSX1204	LSX1804	LSX4000D	LSX5000D
MAX Power @ 1 ohm	NO	NO	1 x4000W	1 x5000W
MAX Power @ 2 ohm	4 x 300W	4 x 450W	1 x1200W	1 x1500W
RMS Power @ 4 ohm	4 x 150W	4 x 225W	1 x 700W	1 x 900W
Bandwidth	10Hz-40KHz	10Hz-40KHz	10Hz-40KHz	10Hz-40KHz
Signal to Noise	≥ 98dB	≥ 98dB	≥ 98dB	≥ 98dB
Channel Separation	≥ 60dB	≥ 60dB	----	----
Input Sensitivity Range	300mv-8v	300mv-8v	300mv-8v	300mv-8v
LP Variable Crossover	40-160Hz&12dB/octave	40-160Hz&12dB/octave	50-150Hz&12dB/octave	40-160Hz&12dB/octave
HP Variable Crossover	40-600Hz/1k&12dB/octave	40-600Hz/1k&12dB/octave	----	----
Variable Bass Boost	0 - +18dB@45Hz	0 - +18dB@45Hz	0 - +18dB@45Hz	0 - +18dB@45Hz
Variable Subsonic Filter	20-55Hz&12dB/octave	20-55Hz&12dB/octave	10-40Hz&12dB/octave	20-55Hz&12dB/octave
High Level Input	YES	YES	----	----
Phase	----	----	0°-180°	0°-180°
Line out RCA jack	YES	YES	YES	YES
RCA Input Model	YES	YES	----	----
Input Impedance	20K Ohms	20K Ohms	10K Ohms	10K Ohms
Damping factor	≥200	≥200	at20Hz 4Ohm≥300	at20Hz 4Ohm≥300
T.H.D (4 Ohm)	0.01%	0.01%	0.01%	0.01%
Fuse Rating	25Ax2	30Ax2	40Ax4	250A
Dimensions(WxLxH) inches	14.41"x 9.57"x2.76"	17.17"x9.57"x 2.76"	17.17"x 9.57"x 2.76"	21.89"x 9.57"x 2.76"

Built-in Crossover

All **Logic** amplifiers feature built-in electronic Crossovers.

The 2/4 Channel amplifiers feature adjustable low pass control.

All **Logic** amplifiers have been designed with 100% MOSFET Power supplies, ensuring extremely quick switching response and self-protection.

Protection Circuitry

The amplifier protection circuitry will disable the amplifier if input overload, short circuit or extremely high temperature conditions are detected. When the protection mode is in operation, the LED indicator on the front panel will be illuminated, indicating the amplifier has gone into a self-preservation mode.

If you observe that the Protection LED is lit, please check the system carefully to determine what has caused the protection circuit to engage. The amplifier can be reset by turning the remote power off and then on again. If the amplifier shut down due to a thermal overload condition, please allow it to cool down before restarting. If the amplifier shut down because of an input overload or short circuit, be sure to repair these conditions before attempting to power the amplifier again.

2 Ohm Operation

Your **Logic**® amplifier was designed to operate efficiently at loads down to 2 Ohms. This means that you can install four 8 Ohm speakers per channel when using parallel wiring. Increasing the number of subwoofers per channel at low frequencies [up to 100 Hz] produces an acoustic coupling effect. This acoustic coupling increases your power output by 3 dB per speaker, or the equivalent of additional 10W to each speaker.

When operating at 2 Ohms, the amplifiers will increase their output power by approximately 50%. The current draw will also increase by about the same amount, so be sure you have enough current to run the amplifiers into a 2 Ohm load, if you lack adequate current, your music reproduction will be distorted.

Please note: The gain control of any car audio amplifier should not be mistaken for a volume control. It is a sophisticated device, designed to match the output level of your audio source unit to the input level of the amplifier. Do not adjust this input level to maximum unless your input level requires it. Ignoring these instructions will result in an input overload to the amplifier, and excessive audio distortion. It can also cause the protection circuit to engage.

Electrical Wiring

All **Logic**® amplifiers are equipped with easy top access screw terminals. These terminals are NICKEL Plated in order to ensure excellent electrical contact, and to resist corrosion.

When making electrical connections to the amplifier, please observe the following:

- Use at least 4 gauge or heavier wires for power and ground connections.
- Wire the amplifier directly to the car battery.
- For the ground connection, use the shortest possible wire to a good chassis ground point.
- Wire the Remote connection to the auto start lead of your equalizer or power antenna.

Fuses

Power fuses protect both the amplifier and the electrical system of your vehicle from fault conditions. If you must replace the fuse in your **Logic**® amplifier, use a fuse of exactly the same type and rating. A different type or rating of fuse may result in damage or fire.

Mounting the Amplifier

Mark the location for the mounting screw holes by positioning the amplifier where you wish to install it and use a scribe [or one of the mounting screws] inserted in each mounting hole to mark the mounting surface. If the mounting surface is carpeted, measure the hole centers and mark with a felt tip pen.

Drill pilot holes in the mounting surface for the mounting screws and insert the mounting screws into these holes. Tighten them securely.

Note: Be sure to take note of any wires, lines or other devices in your vehicle which may be located behind any mounting surface!

Power Supply Connections

Logic Amplifiers are designed to work within 10 to 16 volts DC. Before any wires are connected, the vehicle's electrical system should be checked for correct voltage supply with the help of a volt meter. First check the voltage at the battery terminals with the ignition in the off position. The volt meter should read no less than 12 volts. Next check the battery with the engine running between 1500 and 2000 rpms. The volt meter should now read between 13.5 and 14.5 volts. If your vehicle's electrical system is not up to these specifications, we recommend having it checked by an automotive mechanic before you continue the installation.

Two Channel Amplifier Installation Wiring

LSX1002, LSX1402, LSX2002 AMPLIFIERS

1. Low Input Wiring

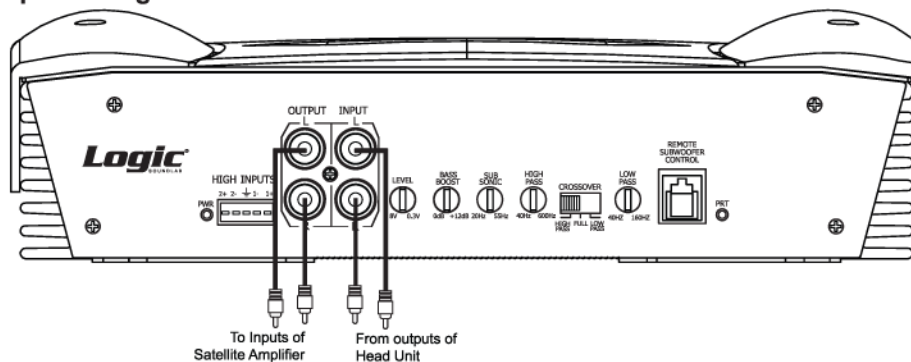

2. High Input Wiring

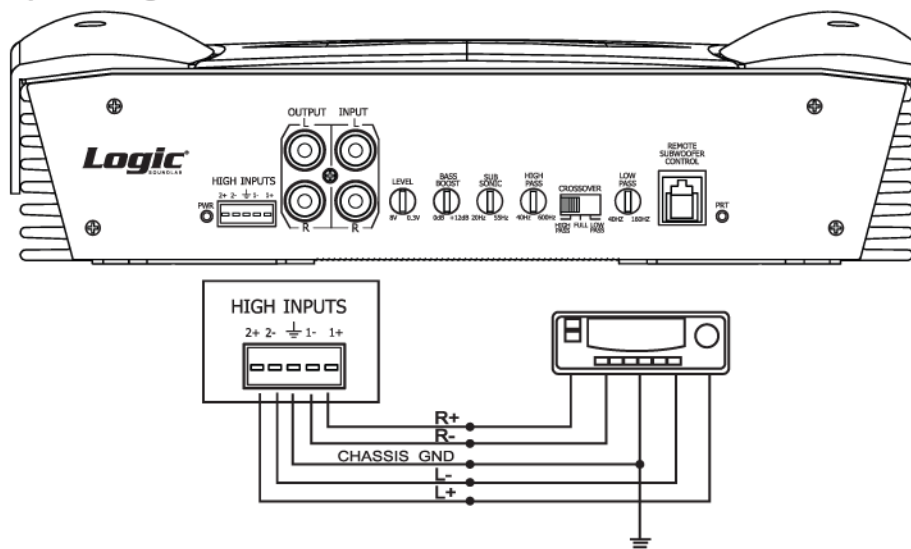

Two Channel Amplifier Installation Wiring

LSX1002, LSX1402, LSX2002 AMPLIFIERS

3.

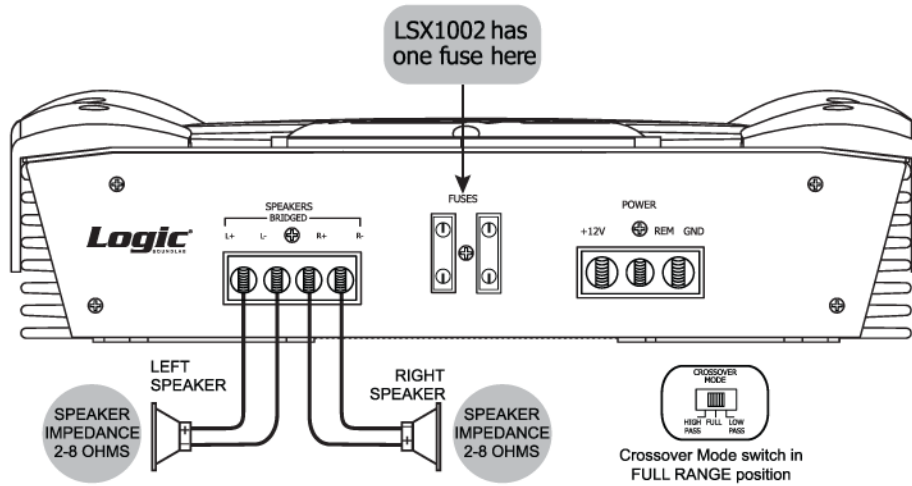

4.

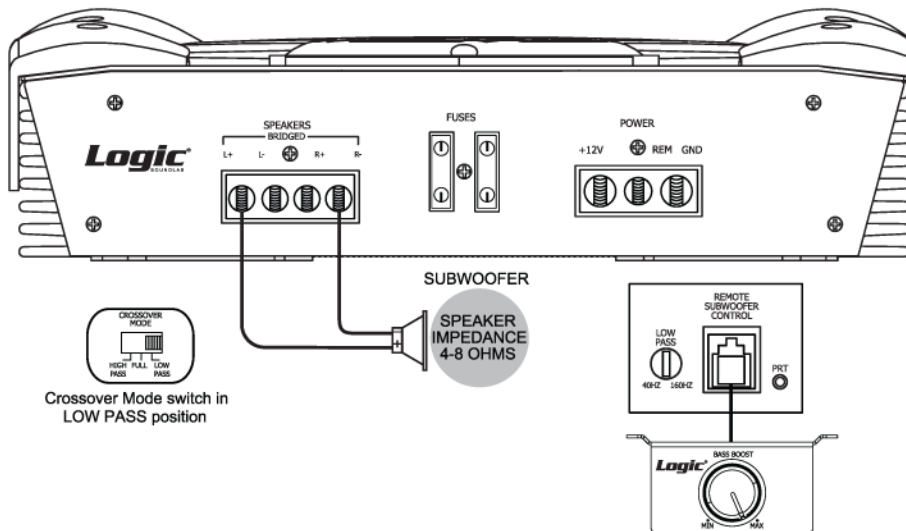

Two Channel Amplifier Installation Wiring

LSX1002, LSX1402, LSX2002 AMPLIFIERS

5.

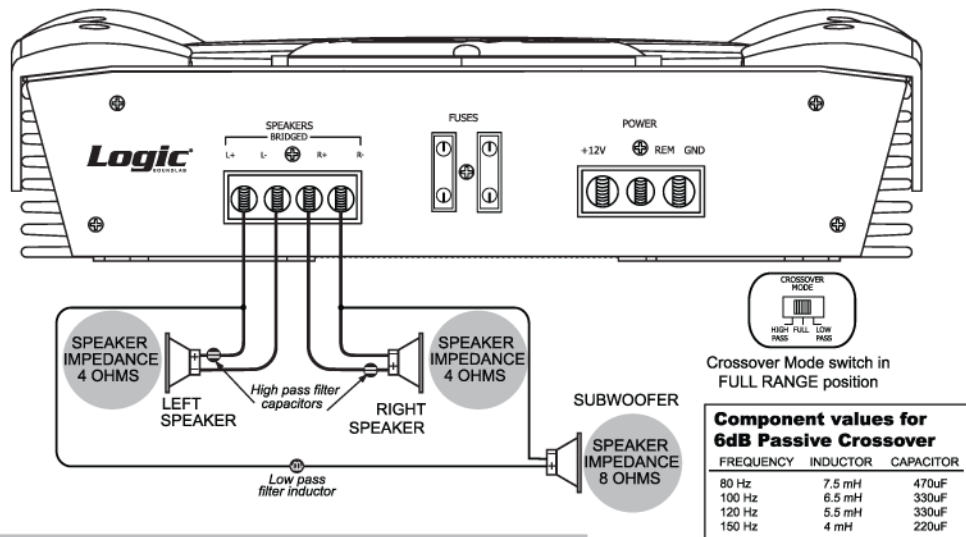

Four Channel Amplifier Installation Wiring

LSX1204, LSX1804 AMPLIFIERS

1. Low Input Wiring

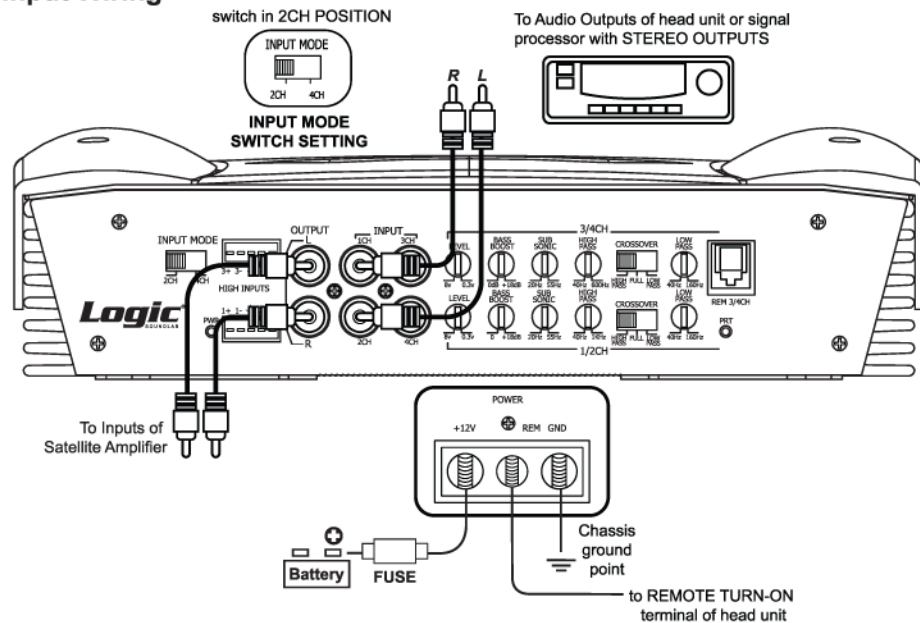

Four Channel Amplifier Installation Wiring

LSX1204, LSX1804 AMPLIFIERS

2. High Input Wiring

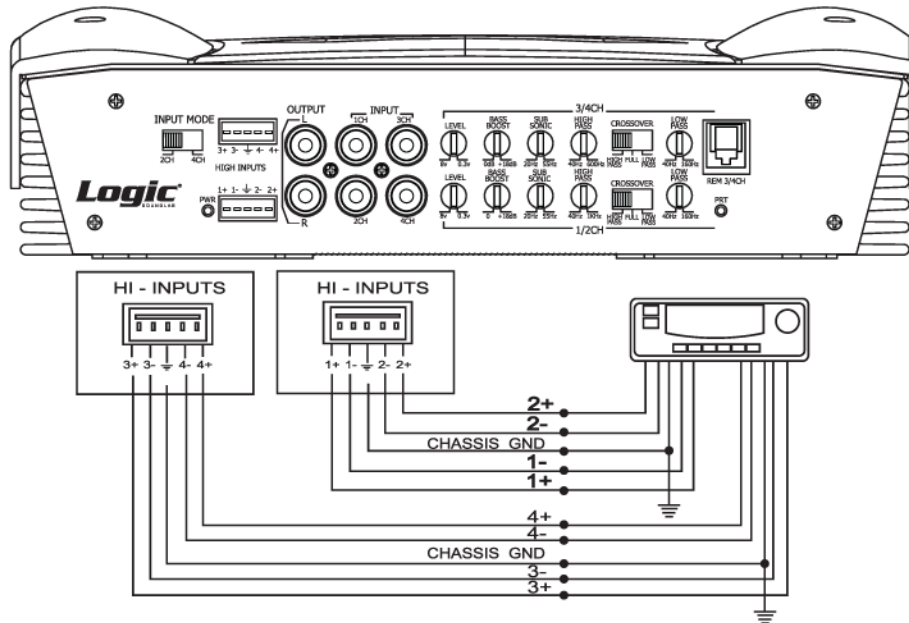

3.

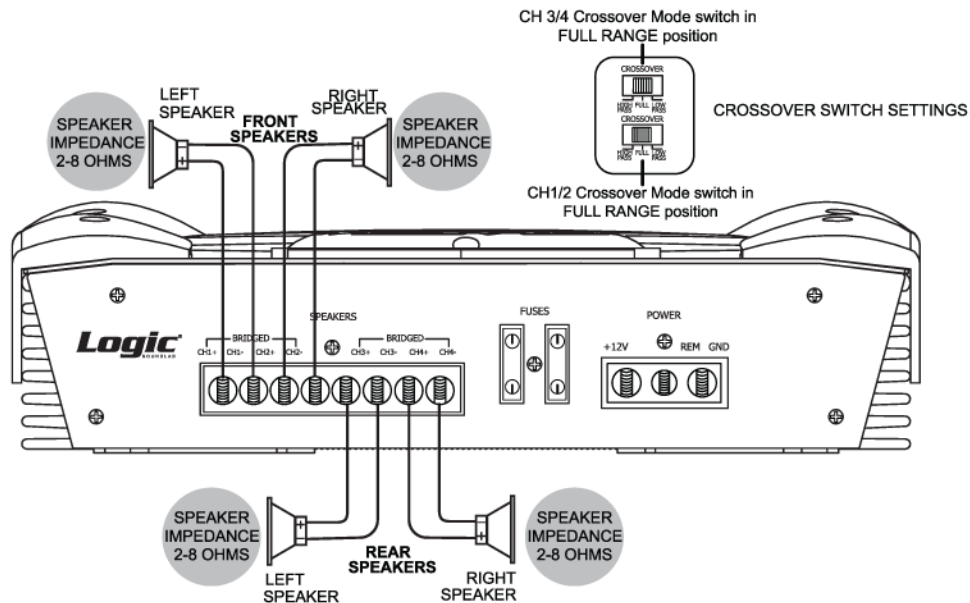

Four Channel Amplifier Installation Wiring LSX1204, LSX1804 AMPLIFIERS

4.

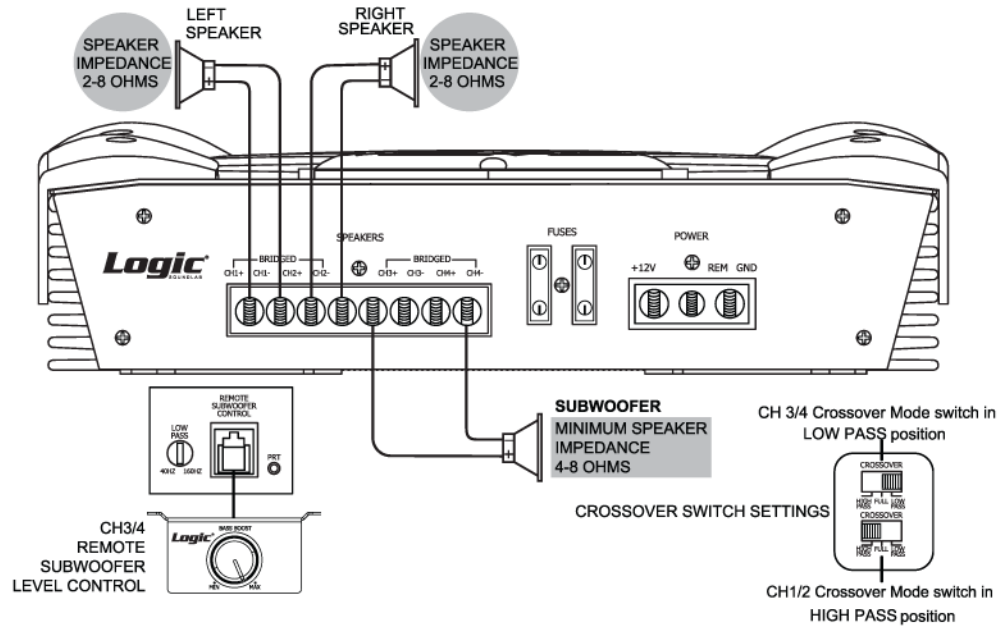

5.

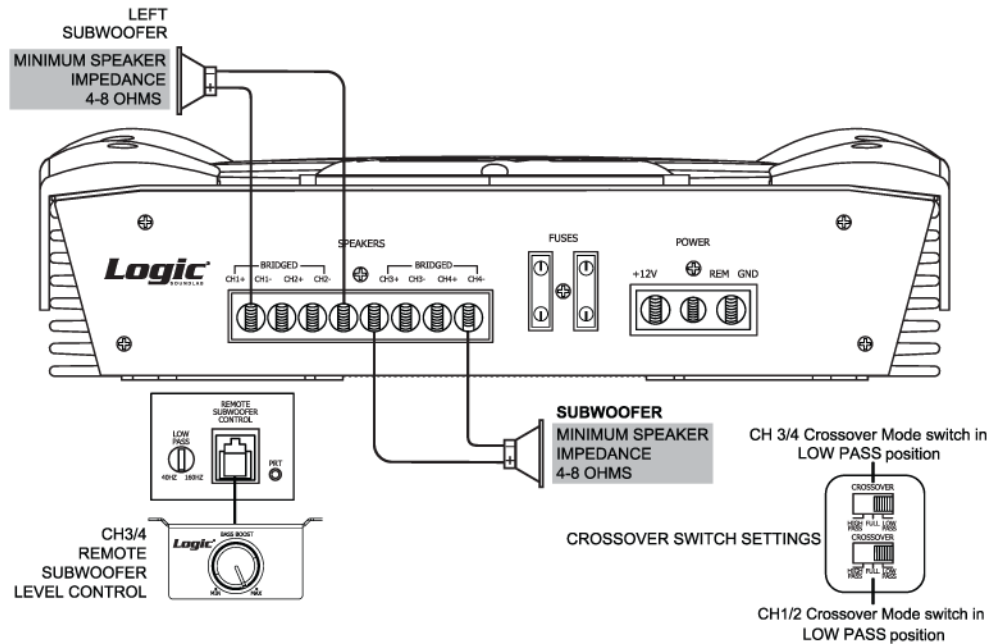

Four Channel Amplifier Installation Wiring

LSX1204, LSX1804 AMPLIFIERS

6.

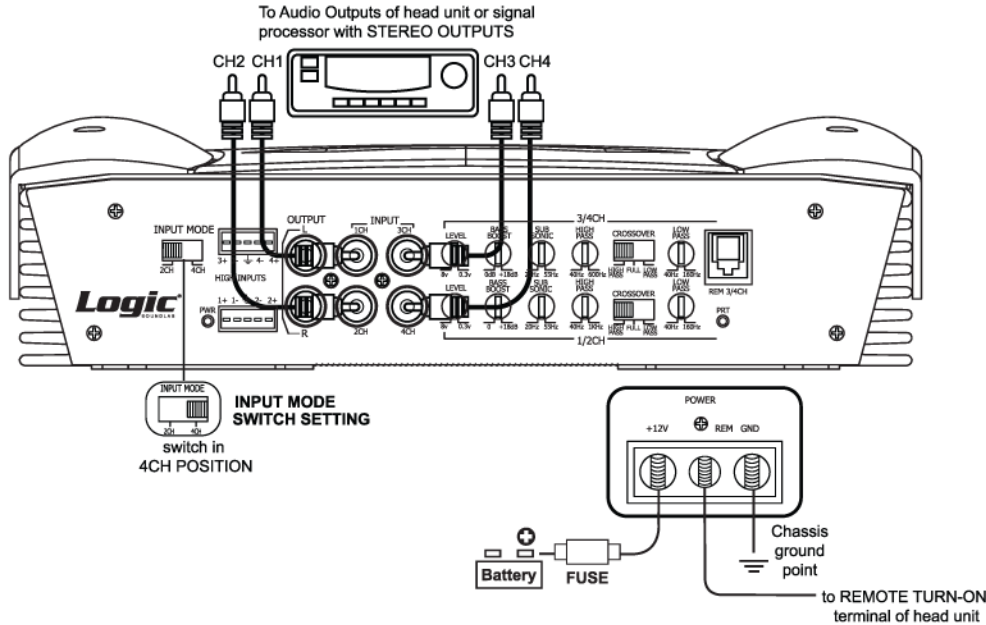

7.

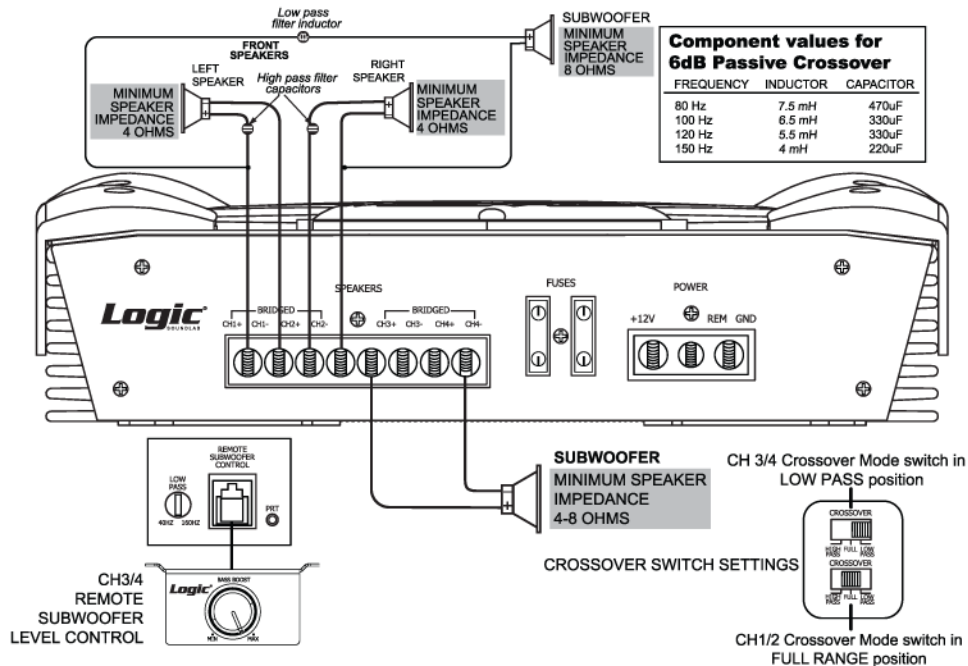

Four Channel Amplifier Installation Wiring

LSX1204, LSX1804 AMPLIFIERS

8.

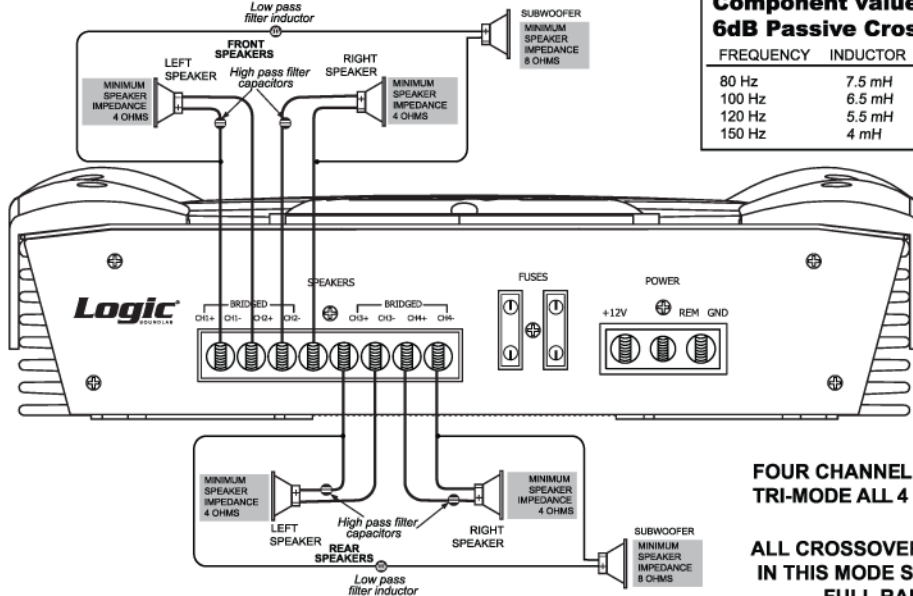

**FOUR CHANNEL AMPLIFIER
TRI-MODE ALL 4 CHANNELS**

**ALL CROSSOVER SETTINGS
IN THIS MODE SHOULD BE
FULL RANGE**

Class D Monoblock Amplifier Installation Wiring

LSX4000D, LSX5000D AMPLIFIERS

1. Low Input Wiring

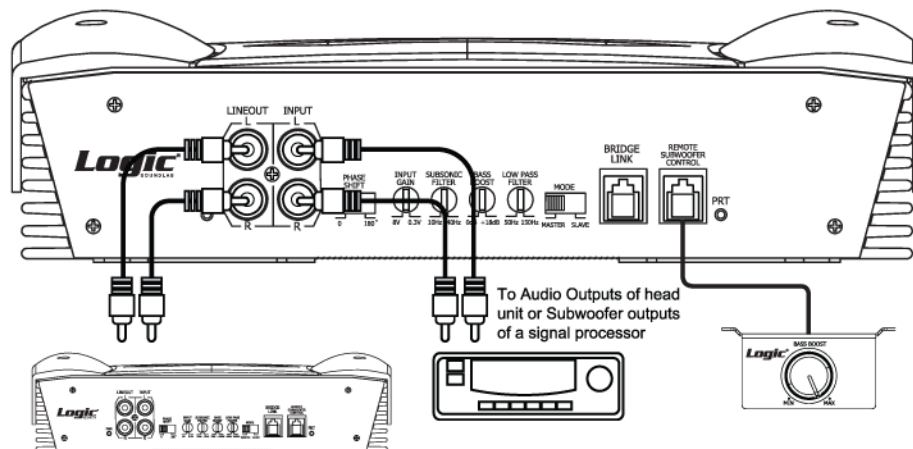

Class D Monoblock Amplifier Installation Wiring

LSX4000D, LSX5000D AMPLIFIERS

2.

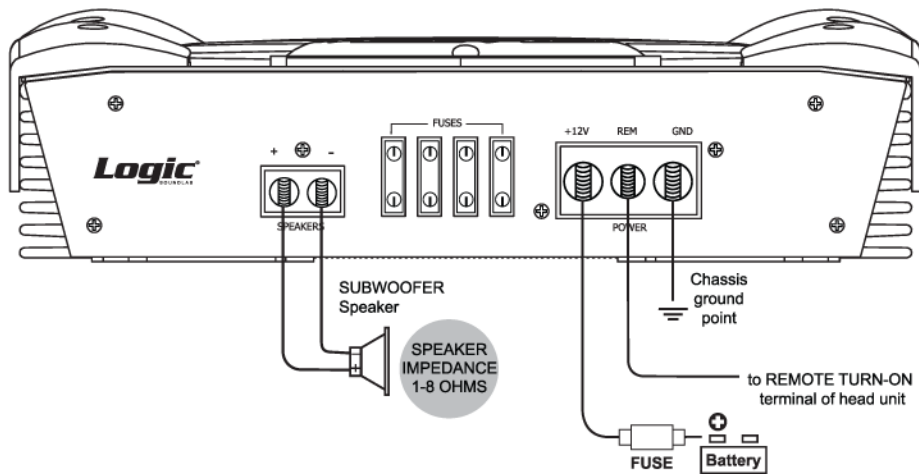

3.

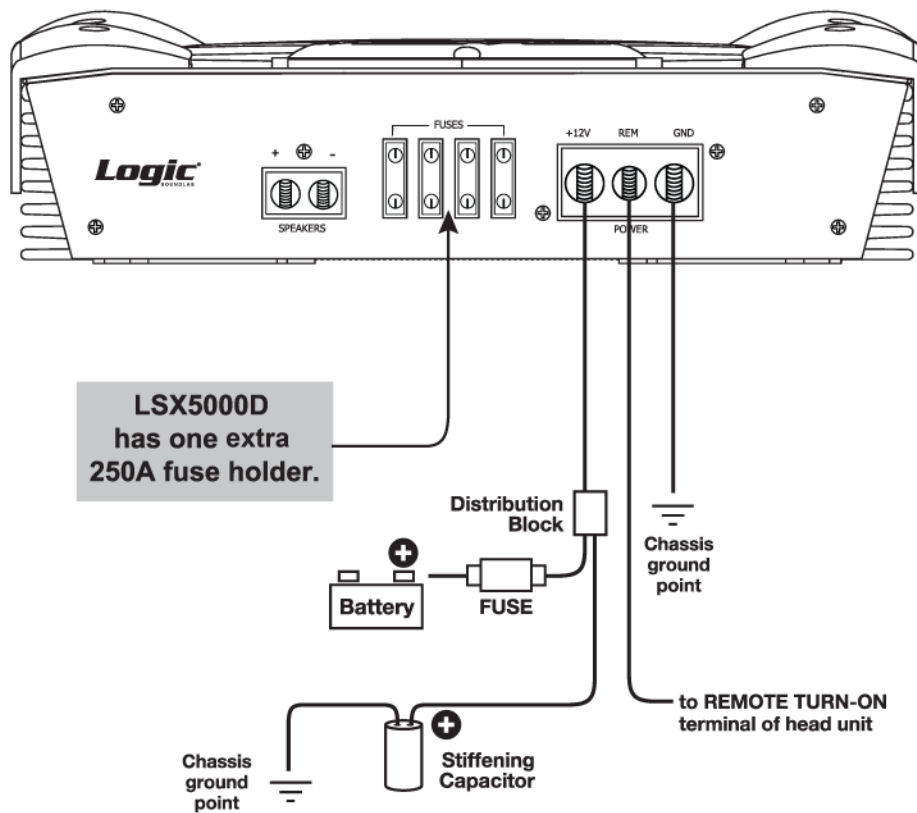

Bridging Two LSX4000D/LSX5000D AMPLIFIERS

INPUT AND DATALINK CONNECTIONS

(SEE NEXT PAGE FOR POWER AND SPEAKER CONNECTIONS)

MASTER AMPLIFIER Front Panel

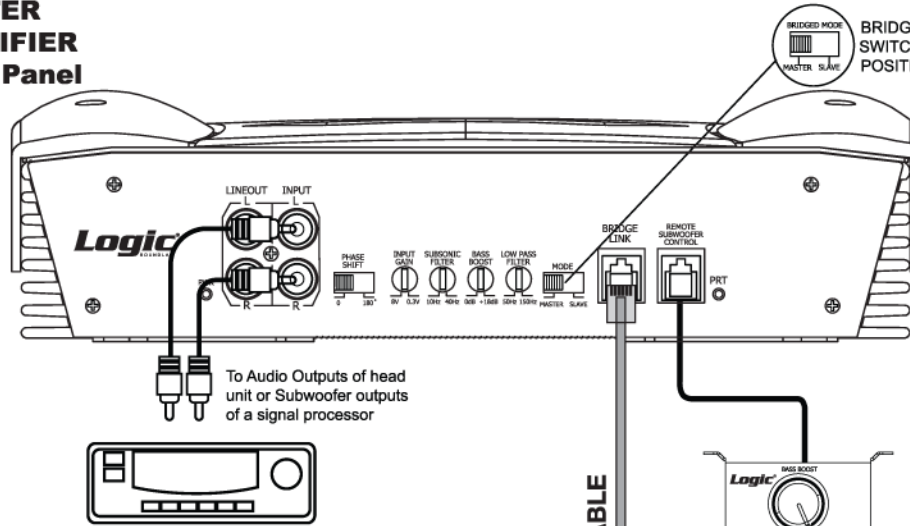

To Audio Outputs of head unit or Subwoofer outputs of a signal processor

SLAVE AMPLIFIER Front Panel

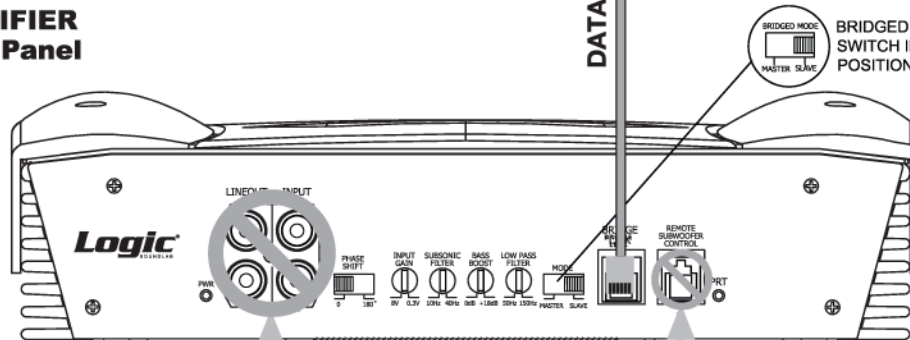

PLEASE NOTE:
In this MASTER AMP/SLAVE AMP configuration, the Slave amp receives its audio signal from the Master Amp. Therefore, **DO NOT USE THE INPUTS ON THE SLAVE AMP!**

PLEASE NOTE:
In this MASTER AMP/SLAVE AMP configuration, the Slave amp receives its audio signal from the Master Amp. Therefore, **DO NOT USE THE SUBWOOFER LEVEL CONTROL ON THE SLAVE AMP!**

Bridging Two LSX4000D/LSX5000D AMPLIFIERS

POWER AND SPEAKER CONNECTIONS

(SEE PREVIOUS PAGE FOR INPUT AND DATALINK CONNECTIONS)

MASTER AMPLIFIER Rear panel

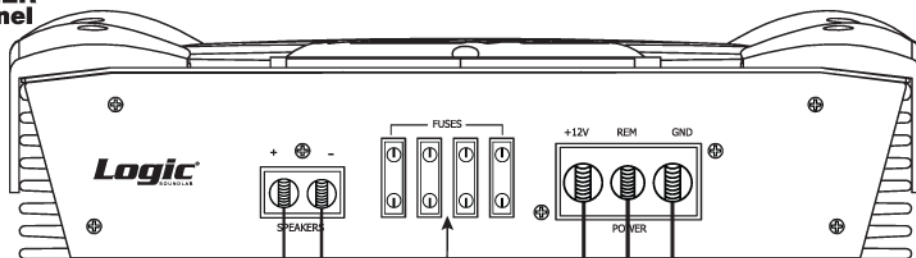

SLAVE AMPLIFIER Rear Panel

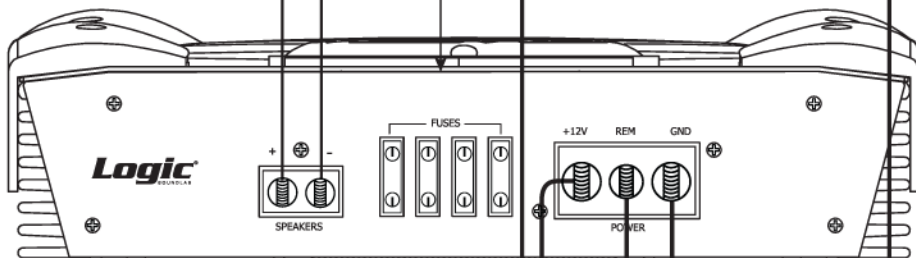

SUBWOOFER speaker

SPEAKER IMPEDANCE
2-8 OHMS

LSX5000D has one extra 250A fuse holder.

Chassis ground point

Distribution Block

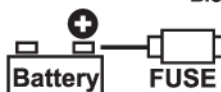

Chassis ground point

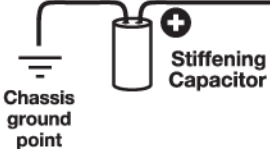

to REMOTE TURN-ON terminal of head unit

Amplifier Disassembly Instructions

1. Unscrew the 8 screws on the four top corners shown in picture 1 and remove the top corners.
2. Unscrew the 8 screws on the front top panel shown in picture 2 after taking out the metal front top panel.
3. Note: Before sliding out the PCB, unscrew the screws on the chrome plated front and rear panel shown in picture 3.

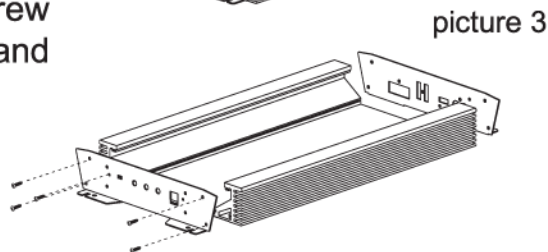
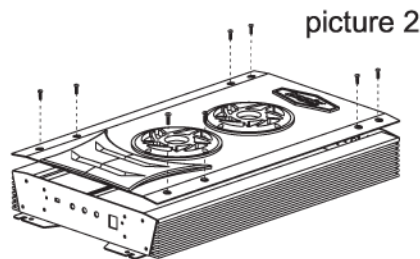
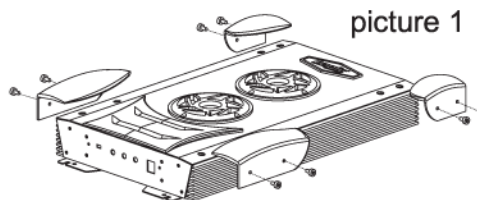

Remote Control

Built-in Remote Jack

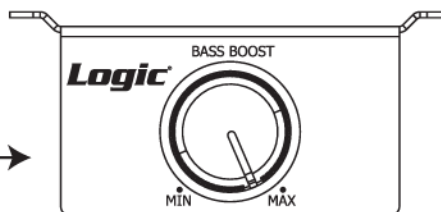
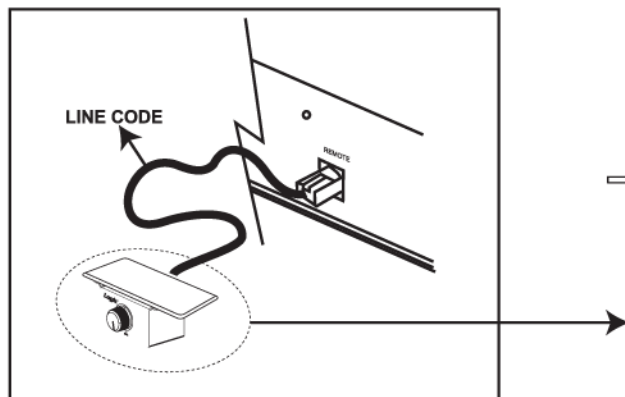

Precautions

Before you drill or cut any holes, investigate your car's layout very carefully. Take care when you work near the gas tank, fuel lines, hydraulic line and electrical wiring.

Do not operate the amplifier when it is unmounted. Attach all audio system components securely within the automobile to prevent damage, especially in an accident.

Do not mount this amplifier so that the wire connections are unprotected or in a pinched condition, or likely to be damaged by nearby objects.

Before making or breaking power connections in your system, disconnect the vehicle battery. Confirm that your head unit or other equipment is turned off while connecting the input jacks and speaker terminals.

If you need to replace the power fuse, only replace it with a fuse identical to that supplied with the system. Using a fuse of a different type or rating may result in damage to your system which isn't covered by the manufacturer's warranty.

Troubleshooting

Before removing your amplifier, refer to the list below and follow the suggested procedures. Always test the speakers and their wires first.

No Output

Confirm that all terminal strip connections are secure and tight.

Check both in-line and built-in fuses. Both the "+ 12V" and the "REMOTE" terminal must have + 12v referenced to chassis ground.

Confirm that the audio signal source [car radio, equalizer, etc.] is connected and is supplying output signal. To check if the amplifier is supplying signal, unplug the RCA cables from the signal source [but leave them plugged into the amp]. Briefly tap the center pin of each of the disconnected RCA plugs with your finger. This should produce a noise [feedback] in your speakers.

Only one Channel works

Confirm that all speaker strip connections are secure and tight.

Check the "BALANCE" control on the head unit [or other source] to verify that it is set to its midpoint.

If you are using the Low Level RCA input, reverse the input plugs at the amplifier [switch the R with the L]. If the channel which is silent switches to the other side, the problem is either in the head unit/other source or the connecting cables.

Weak output Noise in the Audio

Readjust the input Sensitivity Control to better suit input signal.

If the noise is a "whine" whose pitch follows the engine speed, confirm that the amplifier and any other signal sources [head unit, etc.] are properly grounded.

If the noise is a "clicking" or "popping" whose rate follows the engine speed, this usually means that the vehicle is equipped with resistor spark plugs and wires, or that the ignition is in need of service.

Check the routing of the speaker and input wires to make sure they are not adjacent to wires which interconnect lights and other accessories.

If the above steps fail to improve or clear noise interference, the system should be checked by a professional mobile audio installer.



Logic[®]
SOUNDLAB